

Application

Control valve with a tight shutoff of liquids, gases and steam in accordance with DIN or ANSI standards

Nominal sizes	DN 15 to 100	·	NPS ½ to 4
Nominal pressure	PN 16 to 40	·	Class 150 and 300
Ambient temperatures	-35 to 100 °C	·	-30 to 212 °F
Medium temperatures	-50 to 250 °C	·	-58 to 482 °F

The Type 3351 Pneumatic Control Valve consists of an on/off valve and a pneumatic actuator. Optionally, the valve can be equipped with a bellows seal or insulating section.

Valve body made of:

- Cast iron
- Spheroidal graphite iron
- Cast steel
- Cast stainless steel
- Metal-seated and soft-seated valve plug together
- Leakage class VI in accordance with IEC 60534-4 or leakage class VI according to ANSI/FCI 70-2

Attachment of solenoid valves and limit switches according to IEC 60534-6 and NAMUR recommendation. For details, see Information Sheet T 8350 EN.

Versions

Standard version for nominal pressures PN 10 to 40 or Class 150 and 300 with fail-safe action "valve CLOSED" or "valve OPEN"

- **Type 3351-1** (Fig. 1) · On/off valve with self-adjusting PTFE V-ring packing in nominal sizes DN 15 to 100 (NPS ½ to 4) for medium temperatures from -10 to 220 °C (14 to 428 °F)
- **Type 3351-1 · Version with bellows seal**
On/off valve with metal bellows seal and V-ring packing in nominal sizes DN 15 to 50 (NPS ½ to 2) for medium temperatures as listed in Table 1
- **Type 3351-1 · Version with insulating section**
On/off valve with insulating section, plug stem sealed with PTFE V-ring packing, nominal sizes DN 15 to 50 (NPS ½ to 2) for medium temperatures as listed in Table 1

Other versions

- With additional handwheel
- With reinforced spring
- For higher or lower medium temperatures
- For higher ambient temperatures



Fig. 1 · Type 3351-1 Pneumatic On/off Valve



Fig. 2 · Type 3351-1 Pneumatic On/off Valve, Version with handwheel

Principle of operation

Depending on the type of valve seat and the arrangement of the valve plug, the control valve features two different fail-safe actions which are used when the pressure acting on the diaphragm is reduced or when the control signal fails:

Fail-close action

The valve is closed upon supply air failure.

Fail-open action

The valve is opened upon supply air failure.

Direction of flow

The direction of the medium flow in the valve depends on the process medium and the selected fail-safe action.

For valves with fail-close action for applications with gases and vapors, the direction of flow in the closing direction ($A \rightarrow B$) applies, except for the DN 100 version for which the direction of flow in the opening direction ($B \rightarrow A$) is prescribed.

For liquids, the medium **must** flow in the opening direction ($B \rightarrow A$).

For valves with fail-open action, the medium flows in the opening direction ($A \rightarrow B$) regardless of the medium type.

Using the optional handwheel, valves with fail-close action can be opened in case of a supply air failure, and valves with fail-open action can be closed.

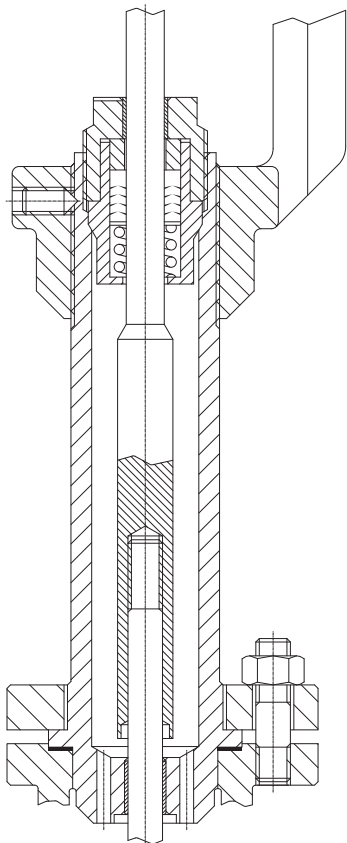

Fig. 3 · Detailed drawing of the insulating section

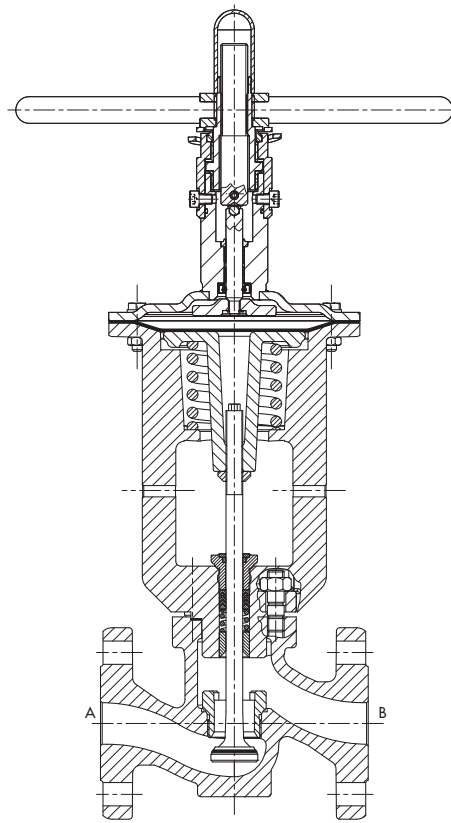

Fig. 4 · Type 3351-1 Pneumatic On/off Valve with handwheel

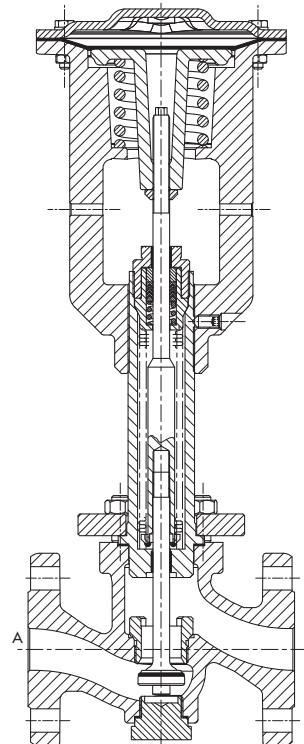

Fig. 5 · Type 3351-1 Pneumatic On/off Valve version with bellows seal

Table 1 · Technical data

Version	DIN				ANSI		
Body material	Cast iron EN-JL 1040	Spheroidal graphite iron EN-JS 1049	Cast steel 1.0619	Stainless cast steel 1.4408	Cast steel A 216 WCC	Cast stainless steel A 351 CF8M	
Nominal pressure	PN 10, 16	PN 10, 16, 25	PN 10, 16, 25, 40		Class 150 and 300		
Nominal size	Standard	DN 15 to 100				NPS ½ to 4	
	Bellows seal/ insulating section	DN 15 to 50				NPS ½ to 2	
Connecting flanges	Form B acc. to DIN EN 1092-1		Form B1 acc. to DIN EN 1092-1		RF		
Temperature ranges in °C (°F) · Permissible operating pressures acc. to the pressure-temperature diagrams (see Information Sheet T 8000-2 EN)							
Ambient temperature	-35 to 100 °C (-30 to 212 °F)				-35 to 100 °C (-30 to 212 °F)		
Medium temperature	-10 to 220 °C (14 to 428 °F)				-10 to 220 °C (14 to 428 °F)		
High-temperature version	-10 to 240 °C (14 to 464 °F) ¹⁾				-10 to 240 °C (14 to 464 °F) ^{1) 4)}		
Low-temperature version	-	-50 to 220 °C (-58 to 428 °F)		-29 to 220 °C (-20 to 428 °F) ⁴⁾	-50 to 220 °C (-58 to 428 °F) ^{3) 4)}		
Leakage class	IEC 60534-4: Class VI				ANSI/FCI 70-2: Class VI		

1) With soft-seated special plug and bellows seal or insulating section

2) Higher temperatures (max. 450 °C/842 °F) with metal-seated plug and leakage class IV or V on request

3) Additional impact test certification required between -29 °C (-20 °F) and -50 °C (-58 °F)

4) With bellows seal or insulating section only

Table 2 · Materials

Valve	DIN				ANSI	
Body	Cast iron EN-JL 1040	Spheroidal graphite iron EN-JS 1049	Cast steel 1.0619	Stainless cast steel 1.4408	Cast steel A 216 WCC	Cast stainless steel A 351 CF8M
Seat	1.4006			1.4404/1.4571	A182 F6a CL2	316Ti/316L
Plug	1.4404 · Seat ring made of reinforced PTFE					
Body gasket	Graphite on metal core					
Actuator diaphragm	NBR (nitrile rubber) with fabric reinforcement · Materials for higher ambient temperatures on request					
Standard version						
Valve bonnet	Spheroidal graphite iron EN-JS 1049	Spheroidal graphite iron EN-JS 1049	Cast steel 1.0619	Valve bonnet 1.4571/1.4404 welded to bonnet 1.0619	Cast steel A 216 WCC	Valve bonnet 316L, welded to bonnet A 216 WCC
Guide bushing	1.4104			1.4404	1.4104	316L
Packing	V-ring packing PTFE with carbon · Spring 1.4310					
Threaded bushing assembly	1.4404 + carbon				316L + carbon	
Version with bellows seal or insulating section						
Bellows seal or insulating section	1.0460			1.4404	A105	316L
Actuator flange	Cast iron EN-JL 1040	Cast steel 1.0619			Cast steel A 216 WCC	
Guide bushing	Fiber-reinforced plastic					
Sealing	Bellows seal: Bellows 1.4571 and PTFE/graphite V-ring packing · Spring 1.4310					
	Insulating section: PTFE/graphite V-ring packing · Spring 1.4310					
Guide nut	1.4404 and fiber-reinforced plastic				316L and fiber-reinforced plastic	
Flange of bellows seal or insulating section	1.0460			1.4301	A105	304

Table 3 · Control pressure and maximum differential pressure · All pressures in bar and psi

Nominal size	DN	15	20	25	32	40	50	65	80	100
(bellows seal or insulating section up to DN 50/NPS 2)	NPS	½	¾	1	–	1½	2	2½	3	4
Flow rate	K _{Vs}	6.3	10	14	25	31	40	72	90	170
	C _v	7.5	12	16	–	36	47	84	105	200
Pneumatic actuator	Effective area in cm ²	60			186			255		700
	Travel in mm	8			10			12.5		30
Max. supply pressure	6 bar/88 psi									
Standard version										
Fail-close										
Min. control pressure to open the valve at Δp _{max}	4 bar/58 psi									
Max. perm. diff. pressure Δp _{max}	Vapor, gas A → B	20 bar/290 psi			16 bar/235 psi			10 bar/145 psi		10 bar/145 psi
	Liquids B → A	16 bar/235 psi			10 bar/145 psi			5 bar/73 psi		
Fail-open										
Min. control pressure to close the valve at Δp _{max}	4.5 bar/65 psi									4 bar/58 psi
Max. perm. differential pressure Δp _{max} with vapors, gases, liquids	20 bar/290 psi			16 bar/235 psi			10 bar/145 psi			
Special version of fail-close version for increased differential pressure Δp										
Min. control pressure to open the valve at Δp _{max}	5.5 bar/80 psi									–
Max. perm. differential pressure Δp _{max} with vapors, gases, liquids ¹⁾	30 bar/435 psi			20 bar/290 psi			7 bar/102 psi		–	

¹⁾ For direction of flow B → A (see Fig. 4)

Table 4 · Dimensions for Type 3351

Valve	DN	15	20	25	32	40	50	65	80	100	
	NPS	½	¾	1	–	1½	2	2½	3	4	
Length L	PN 10/40	mm	130	150	160	180	200	230	290	310	350
	Class 150	in	7.25			–	8.75	10	10.88	11.75	13.86
		mm	184			–	222	254	276	298	352
	Class 300	in	7.50	7.63	7.75	–	9.25	10.50	11.50	12.50	14.49
in		191	194	197	–	235	267	292	318	368	
Diaphragm diameter	mm	150			240			280		390	
Loading pressure connection	α	G ¼			G ¼			G ⅝			
Standard version											
H1	mm	260			285			328		485	
H2	mm	45			72			98		118	
H3 ¹⁾	mm	380			380			415		565	
Version with bellows seal or insulating section											
H4	mm	400			415			–			
H2	mm	55			80						
H3 ¹⁾	mm	520			535						

¹⁾ Minimum clearance for removing the actuator; version with handwheel: add 150 mm for DN 80 or smaller; add 210 mm for DN 100

Table 5 · Weights for Type 3351

Standard version	DN	15	20	25	32	40	50	65	80	100	
	NPS	½	¾	1	–	1½	2	2½	3	4	
Weight, approx. kg	PN 10/40	11	12	12	25	26	29	48	52	70	
	Class 150	11	12	13	–	23	27	47	52	64	
	Class 300	12	13	14	–	25	29	50	52	64	
Version with bellows seal or insulating section											
Weight, approx. kg	PN 10/40	16	17	17	33	34	37	–			
	Class 150	16	17	18	–	31	35				
	Class 300	17	18	19	–	33	37				

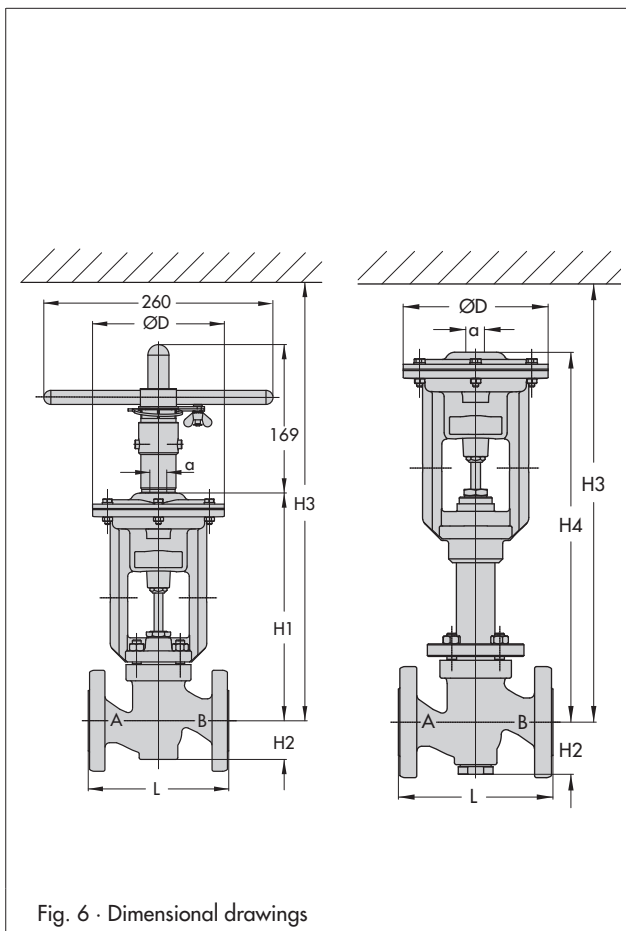

Fig. 6 · Dimensional drawings

Ordering text

Type 3351 Pneumatic On/off Valve

Nominal size DN/NPS

Nominal pressure PN/Class

Body material According to Table 1

Fail-safe action Fail-close or fail-open

Control pressure ... bar

Handwheel Without / with

Special versions Bellows seal/insulating section
Version for high or low temperatures

Accessories Solenoid valve and/or
electric or pneumatic limit switch

Specifications subject to change without notice.



SAMSON AG · MESS- UND REGELTECHNIK
Weismüllerstraße 3 · 60314 Frankfurt am Main · Germany
Phone: +49 69 4009-0 · Fax: +49 69 4009-1507
Internet: <http://www.samson.de>

T 8039 EN

2012-11